

ADAPTOR SMA MALE - TNC FEMALE

R191.311.000

Série : ADAPT

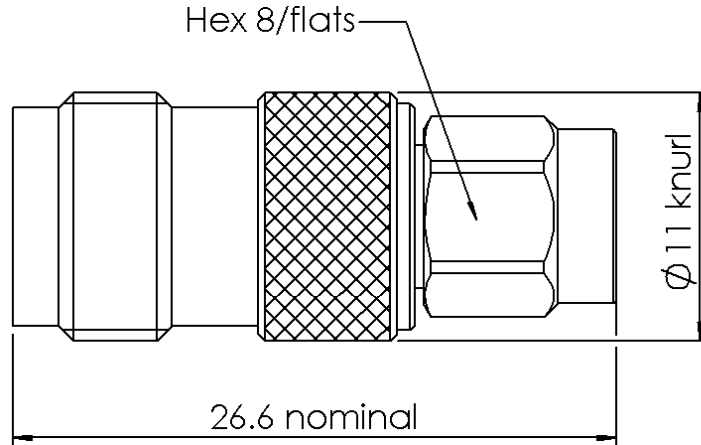

All dimensions are in mm.

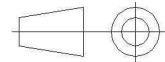

COMPONENTS	MATERIALS	PLATING (µm)
BODY	BRASS	NICKEL 2
CENTER CONTACT	BERYLLIUM COPPER	GOLD 2.5 OVER NICKEL 2
OUTER CONTACT	-	-
INSULATOR	PTFE	
GASKET	SILICONE RUBBER	
OTHERS PARTS	BERYLLIUM COPPER	NICKEL 2
-	-	-
-	-	-

Issue : 0922 L

In the effort to improve our products, we reserve the rights to make changes judged to be necessary.



ADAPTOR SMA MALE - TNC FEMALE

R191.311.000

Série : ADAPT

PACKAGING

SPECIFICATION

Standard	Unit	Other
1		Contact us

ELECTRICAL CHARACTERISTICS

ENVIRONMENTAL

Impedance		50 Ω
Frequency		0-11 GHz
VSWR	1.05 +	0,0250 x F(GHz) Maxi
Insertion loss		0.1 √F(GHz) dB Maxi
RF leakage	- (60 - F(GHz)) dB Maxi
Voltage rating		335 Veff Maxi
Dielectric withstanding voltage		750 Veff mini
Insulation resistance		5000 MΩ mini

Operating		-65/+125 °C
Hermetic seal		NA Atm.cm3/s
Panel leakage		NA

MECHANICAL CHARACTERISTICS

OTHER CHARACTERISTICS

Center contact retention		
Axial force – Mating end		27 N mini
Axial force – Opposite end		27 N mini
Torque		NA N.cm mini
Recommended torque		
Mating	SMA	0 N.cm
	TNC	0 N.cm
	-	0 N.cm
Panel nut		NA N.cm
Mating life		500 Cycles mini
Weight		10,000 g

Issue : 0922 L

In the effort to improve our products, we reserve the rights to make changes judged to be necessary.

